

# Verso R 1000 FSA C5

Nominal air flow according to ErP 2018, m <sup>3</sup> /h	1000
Nominal air flow according to ErP 2018, l/s	278
Electric air heater capacity, kW / Δt, °C	3/8,8
Supply voltage HE, V	3~400
Maximal operating current HE, A	7,8
Power supply cable E, mm <sup>2</sup>	5×1,5
Electric power input of the fan drive at maximum flow rate, W	115
Noise power level, L <sub>WA</sub> , dB(A)	43
Noise pressure level, L <sub>PA</sub> , dB(A), (3 m)	31
Filters dimensions B×H×L, mm	472×402×96
Supply filter class	ePM1 60 (F7)
Exhaust filter class	ePM10 50 (M5)
Unit dimensions B×H×L, mm	1050×485×3000
Panel thickness, mm	50
Maintenance space, mm	660
Unit weight, kg	238

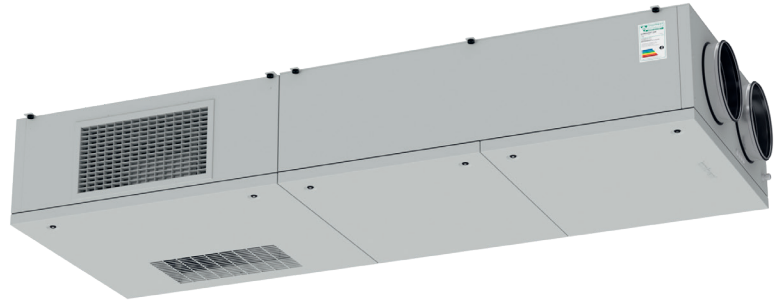

## Performance

Verso R 1000 FSA with standard equipment

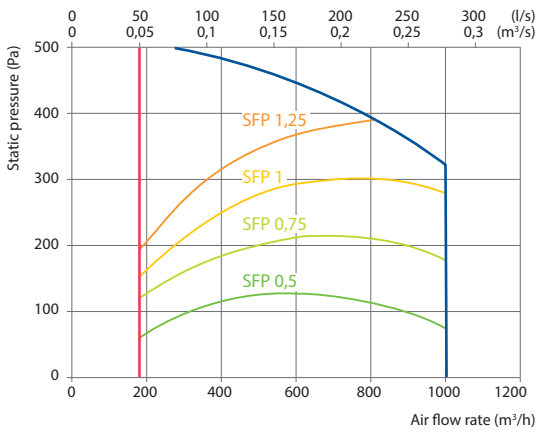

## Temperature efficiency

Outside temperature, °C	Winter					Summer		
	-23	-15	-10	-5	0	25	30	35
After heat exchanger, °C	13	14,6	15,6	16,6	17,6	22,6	23,6	24,6

Indoor +22 °C, 20 % RH

Shown as right (R1)

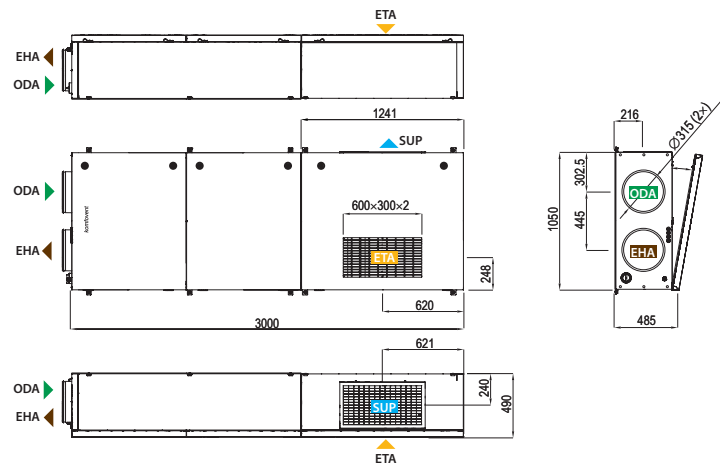

Shown as left (L1)

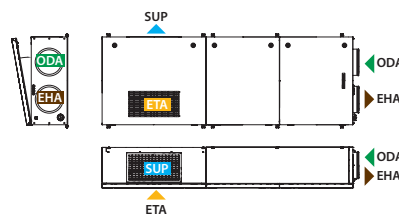

## Accessories

Closing damper	AGUJ-M-315+LM24
Outdoor grill	LD-315

## Mounting positions



▶ ODA – outdoor intake    ▶ SUP – supply air    ▶ ETA – extract indoor    ▶ EHA – exhaust air